

KING CRACKERS

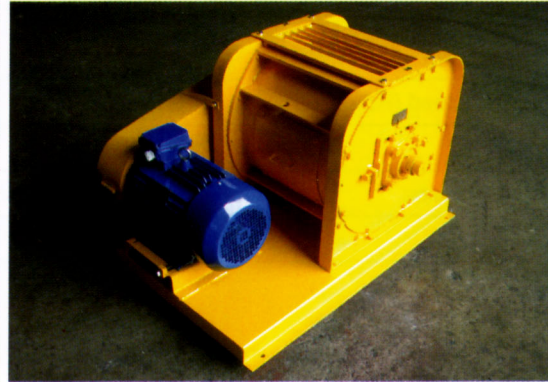

The revolutionary nut cracker for cracking nuts has consistent high cracking efficiency. Easy and low cost maintenance. No more re-building of ripple plate with welding.

FEATURES

1. Uses stator rods which can be renewed by dismantling of non-drive end side plate.
2. Bearing housings are designed for easy dismantling and adjustment.
3. Two sided stator rod to minimise maintenance downtime.
4. Hardness of the rods are more consistent than conventional hard-facing.

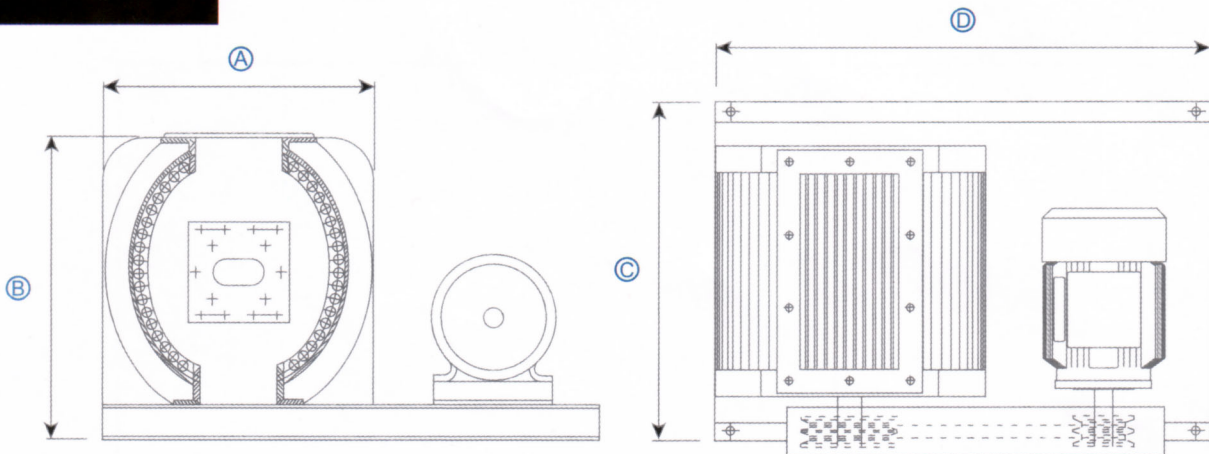

INSTALLATION / SHIPPING DATA (All dimension are in millimeters)

Model	A	B	C	D	Wgt(Kg)	Shipping Vol (m3)
CB 4T KING CRACKER	620	625	590	1040	420	0.8
CB 6T KING CRACKER	620	625	695	1040	460	1.0
CB 8T KING CRACKER	890	940	820	1450	800	1.9

SPECIFICATIONS

Model	CB 4T KING CRACKER	CB 6T KING CRACKER	CB 8T KING CRACKER
Capacity (Kg/Hr)	4000	6000	8000
Motor (kW)	5.5	7.5	15
No. of Rotor Rod	34	34	44
No. Of Stator Rod	36	36	36
Rotor Speed (Rpm)	1000		
Bearing	SKF or equivalent		
Transmission	V belt via taper lock pulley		
Efficiency	Up to 99%		

Modipalm Engineering Sdn. Bhd. reserves the right to change all specifications and dimensions without prior notification.

Distributed by:



MODIPALM ENGINEERING SDN. BHD. (210753-U)
(A wholly owned subsidiary of CB Industrial Product Holding Berhad)
Lot 3 & 4, Jalan Waja 15, Kawasan Perusahaan Telok Panglima Garang,
42500 Telok Panglima Garang, Selangor Darul Ehsan. MALAYSIA.
Tel: (6) 03 - 3122 7117, 3122 8899 (Gen. Line)
Fax: (6) 03 - 3122 7152, 3122 9152
Email: info@modipalm.com.my

Visit our website: www.modipalm.com.my